



OPERATIONS AND REPAIR MANUAL

MODEL REM 500 NEUTRON SURVEY METER

INCLUDES SECTION ON MCA OPTION

September 1998 Revision A

The REM-500 contains a small check source. Please read the section on Radioactive material.

health physics instruments

330 D South Kellogg Ave, Goleta, CA 93117 Tel 1-805-967-8422

TABLE OF CONTENTS

SPECIFICATIONS	ii
I. INTRODUCTION	1
II. GETTING STARTED	1
III. MODES OF OPERATION.	2
IV. CHANGE MODE	3
V. BUTTONS	5
VI. OVERFLOW, AND HIGH RADIATION LEVELS	6
VII. SHOCK	7
VIII. LOW BATTERY.	7
IX. BATTERY REPLACEMENT	7
X. FAILURE	8
XI. STATISTICS AND COUNTS	8
XII. CHECK MODE.	8
XIII. MULTICHANNEL ANALYZER MODE.	9
XIV. SERIAL COMMUNICATIONS	10
XV. PRINCIPAL OF OPERATION	11
1. ELECTRONICS/SOFTWARE.	11
2. DETECTOR	12
XVI. CALIBRATION MODE	13
XVII. CALIBRATING THE INSTRUMENT	16
XVIII. RADIOACTIVE MATERIAL INSIDE DETECTOR	18
XIX. MAINTENANCE MODE	19
XX. CIRCUIT DESCRIPTION	20
XXI. ELECTRONIC ADJUSTMENTS	23
XXII. TROUBLE SHOOTING NOTES	25
XXIII. QUALITY FACTORS	26
XXIV. PARTS LIST	27
XXV. PARTS LOCATION AND SCHEMATICS	31

SPECIFICATIONS

- MECHANICAL** Size: 12"L x 4.5"W x 4.5"H excluding handle, handle extends height to 6.25".
- Weight: 5 lbs, 2 oz including alkaline batteries.
- External Controls: 5 pushbutton switches for POWER ON/OFF, MODE, ALTERNATE, RESET and LIGHT.
- Internal Controls: Cal and Reset pushbutton; Coarse Contrast, Pole Zero, High Voltage, and LLD trimpots.
- DETECTOR** Type: Sealed Spherical TE Proportional Counter. Rossi Type. 2 1/4" ID.
- Wall Material: A150 Conducting Tissue Equivalent plastic.
- Wall Thickness: 0.12 cm, 144 mg/cm, Aluminum can .065"
- Filling Gas: Propane gas, 2 micron
- Internal Source: Less than 1 uCi Cm244
- OPERATIONAL** Readout: Alphanumeric 2 line x 16 character LCD
- Range: Autoranging from .001 mREM/h to 999 REM/h and .001 mRAD/h to 999 RAD/h rate and .001 mREM to 999 REM and .001 mRAD to 999 RAD integrate. SI units of Sv and Gy are also selectable.
- Multi-Channel Analyzer: 256 Channel MCA. 65535 counts/channel. RS-232 serial link can control MCA operation.
- Temperature Dependence: less than $\pm 15\%$ from 15 to 45°C
- Humidity Response: Less than 10 % change from 0 to 95 % RH non condensing.
- Neutron Energy Response: 70 KeV to 20 MeV
- Gamma Response: Less than 1% at 1 RAD/h.
- Warm Up Time: 15 seconds
- Battery Life: 100 hours; 6 ea alkaline C cells.
- Serial RS232 link: In Rate and Integrate mode, sends radiation level on command. In MCA mode dumps MCA raw channel data, count time, total counts and Instrument Calibration Factor. Baud rate is 9600. Available if the MCA option is installed.

PLEASE NOTE:

All of the descriptions and examples throughout the manual use the units of Rem and Rad. Si units of Sv and Gy are also available. To select the Si units please refer to the Calibration section.

This manual covers the REM-500 with or without the MCA option. To check if the MCA option is installed, look on the front panel. If the panel contains a jack on the lower right for a connector, then the MCA option has been installed.

I. INTRODUCTION

The Rem 500 is a Neutron Survey Meter that reads in both REM and RADS. It is a small light portable instrument that is at home both in the field and in the lab. This manual describes its operation and use.

II. GETTING STARTED

The instrument is very easy to use. There are only 5 controls across the top of the instrument. All of the controls are push buttons. To turn the instrument on, push the **ON/OFF** button. The instrument will first do a self test and wait until it stabilizes. The countdown shows how much longer to wait and also shows that the instrument is functioning.

REM 500 SELF TEST	10
----------------------	----

TURN ON DISPLAY

When the instrument is finished with the opening display, it goes into normal operation. It may show a small amount of radiation on the first display. You will notice in the upper right hand corner a countdown of seconds. When it gets to zero it displays the next reading and then recycles. The lower left of the display shows the time constant, in seconds. The lower right shows the number of counts acquired during the time constant period.

.000 mREM/h 10sec TC	9 0ct
-------------------------	----------

Changing from REM to RAD is very easy, just push the **ALT** button. Each time it is pressed it changes from RAD to REM or from REM to RAD. It just alternates back and forth between the two.

ON/OFF	MODE	ALT	RESET	LIGHT
●	●	●	●	●

FRONT PANEL

If you are having difficulty seeing the display because you are in dim light, pushing the **LIGHT** button will turn on the display backlight for 15 seconds.

To freeze the display, push the **RESET** button. The word **HOLD** will appear in the upper right hand corner of the display. The reading is

now frozen. Pushing the **RESET** button again will reset the instrument and put it back into normal operation.

To change from the rate mode of operation, to the integrate mode, just push the **MODE** button twice. To get back to the RATE mode, again push the **MODE** button twice. Switching back and forth between rate and integrate is very easy, just push the **MODE** button twice.

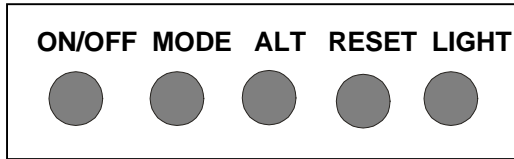

FRONT PANEL

The integrate mode has a slightly different display. The Integrate time is shown on the lower left. The counts that have been acquired remain on the lower right. The upper right is blank. The **ALT**, **RESET**, and **LIGHT** buttons work in this mode just like the rate mode.

You have now run the instrument through its basic operation. More areas of the instrument are discussed in the following sections. Remember you cannot hurt the instrument if you push the wrong button at the wrong time. Turning it on and off will restore it to normal operation.

III. MODES OF OPERATION

There are three main modes of operation, rate, integrate, and Multichannel Analyzer (if installed). Rate and integrate are discussed here. See the Multichannel Analyzer section for a description of that mode. In addition there is a Check mode which is discussed in the Check Mode section. Each mode can be identified by the arrangement of the display. See the MCA mode section for a description of the Multichannel Analyzer.

RATE MODE

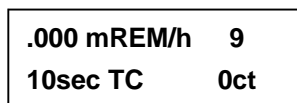

FIGURE # 1
RATE DISPLAY

Figure 1 shows the RATE display. When first turned on, the instrument is in this mode. The integrate mode can be reached by pushing **MODE** twice from the Rate mode.

The radiation level, autoranging from .001 mREM/h to 999 REM/h, is shown on the upper left. If the instrument is reading RADS, then it will show between .001 mRAD/h and 999 RAD/h. It indicates over range by showing >1K REM/h (or >1K RAD/h if reading in RADS) in the display. The lower left shows the current time constant. The instrument gathers data for the time constant period then displays it. The upper right hand corner of the display shows the time remaining in this period. There are 3 Time Constant settings; 10, 30, or 60 seconds. The number in the upper right corner of the display shows the time remaining in this time constant period. Each reading is completely separate from any other reading.

The lower right hand corner shows the number of events that have been counted during this period. When the **HOLD** button is pushed the word HOLD will ap-

pear in the upper right corner of the display. If the battery is bad, the word LBAT will flash in the same place.

INTEGRATE MODE

.000 mREM	
00:00:10	Oct

FIGURE # 2
INTEGRATE DISPLAY

Figure 2 shows the Integrate display. The Integrate display can be reached by pushing **MODE** twice from the RATE display. The display is updated every 10 seconds. The radiation level, autoranging from .001 mREM to 999 REM, is shown on the upper left. If the instrument is reading RADS, then it will show between .001 mRAD and 999 RAD. It indicates over range by showing 1K REM (or 1K RAD if reading in RADS) in the display.

The lower left shows the time of integration. It displays the time in HRS:MIN:SEC and will go as high as 18 hrs, 12 min and 15 seconds before it resets to zero. It updates every second. The lower right hand corner shows the number of events that have been counted. When the HOLD button is pushed, the instrument recalculates the level for that second then updates the display and shows HOLD in the upper right hand corner. Switching between REM and RAD, when on hold, using the **ALT** button, will show the two levels. If the battery is bad, the word LBAT will flash in the upper right hand corner.

The instrument will continue to gather data until it is reset.

IV. CHANGE MODE

↓NEXT

Soft Keys are shown with an arrow.

The change mode allows adjustment of the display contrast and time constant; it is also a way into the Check mode.

There are five levels of displays that can be shown besides the rate and integrate displays. We have named them level 1, level 2, level 3, check and MCA. You may have noticed level 1 when you switched between the rate and integrate modes. On these displays the meaning of the keys are changed. The new meaning is shown on the display with arrows pointing to the corresponding key. The keys that are re-defined in all except the MCA mode are the three middle keys. The **LIGHT** key is not changed except in the MCA mode. The **ON/OFF** key is not changed.

The five levels are shown below. To get to level 1 push the **MODE** key once. To get to level 2 just push the ↓**NEXT** key. To get to level 3 just push the ↓**NEXT** key again, and to get back to normal operation, just push the ↓**NEXT** key again. If you are in the Check display, pushing ↓**NEXT** will get you back to normal operation. The same is also true for the MCA mode. *Pushing the ↓**NEXT** key repeatedly will always get you back to normal operation.*

LEVEL 1 MENU

INT	RATE	NEXT
↓	↓	↓

This is the display for the Level 1 menu if the instrument was in the Integrate mode when the **MODE** button was pushed. You will note that the new definition of the **MODE** button is **RATE**. If the instrument was in the RATE mode when the **MODE** button was pushed, then the display would look like the next example. This change of definition of the key is the way it is possible to switch between the Rate and Integrate mode just by pushing the mode button twice. To exit this menu push either the INT or RATE and you will be back in normal operation. ↓**NEXT** moves you to the next display as shown below.

LEVEL 2 MENU

TC	DISPL	NEXT
10↓	↓	↓

This is the display for the LEVEL 2 MENU. It allows adjustment of two items, the Time Constant or TC and the display contrast. Pushing the buttons under each one changes the corresponding item. For example, pushing the ↓TC button would change the TC from 10 to 30. Pushing the ↓DISPL button would change the contrast 1 level. ↓**NEXT** moves you to the next display as shown below.

LEVEL 3 MENU

CHECK	MCA	NEXT
↓	↓	↓

MCA will show only if the MCA option is installed.

This is the Check menu that only allows you to go into the check or MCA mode. Pushing the ↓**CHECK** button changes into the Check menu. Pushing the ↓**MCA** button (if installed) changes into the MCA menu. The ↓**NEXT** button returns you to normal operation.

CHECK MENU

LFT	PK	RT	NEXT
080	090	100	↓
00:00:00	OCT		

This is the Check menu. The numbers under the LFT, PK and RT will be calculated, the numbers shown are just for reference. See the Check section for an explanation of Check. ↓**NEXT** returns you to normal operation. A detailed discussion of the function of each key is discussed in the Buttons section.

MCA MENU

This is the Multichannel or MCA menu. This mode allows the instrument to gather data and then download the data to a computer on an RS232 serial link. The remote computer can also control the operation of the MCA. See the MCA section for a complete explanation of the MCA. ↓**NEXT** returns you to normal operation.

V. BUTTONS

There are 5 buttons on the front of the instrument. Their operation is described below.

ON/OFF Turns the instrument on and off. If the instrument is on, pushing it will turn it off. If it is off, pushing it will turn it on.

MODE Selects the various modes and displays. Pushing it twice will switch between rate and integrate and vice versa. Pushing it once will enter the menu of Level 1.

ALT ALT is for ALTERNATE which selects between REM and RAD. If the instrument is reading in REM pushing the **ALT** will switch to RAD. If the instrument is reading in RAD, pushing it will change to REM. When in the Rate mode, switching between REM and RAD will reset the data even if the instrument is on hold. This is not true for the Integrate range. If the instrument is on hold, then switching between RAD and REM will not reset the data.

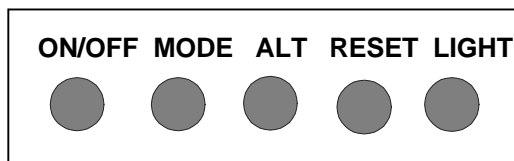

FRONT PANEL

RESET Puts the instrument in either a Hold mode, or resets it. The first push of the button holds the data. The display will show HOLD in the upper right hand corner to let you know that the instrument is in hold. Pushing the button again will reset the instrument and it will resume normal operation. If the instrument is on HOLD and in the integrate range, the **ALT** button will change between RAD and REM on the same data without resetting the instrument.

LIGHT Turns on the light for 16 seconds. If you are in the various menu's, pushing the light will keep it on until you go back to normal operation.

*NOTE: To reach LEVEL 1 from normal operation push **MODE**.*

LEVEL 1 ↓**INT** Puts the instrument into the Integrate mode.

LEVEL 1 ↓**RATE** Puts the instrument into the Rate mode.

LEVEL 1 ↓**NEXT** Changes from level 1 to level 2

*NOTE: To reach LEVEL 2 from normal operation push **MODE**, ↓**NEXT**.*

LEVEL 2 ↓**TC** Changes the Time constant of the instrument for the Rate mode. Each time it is pressed it changes to the next time constant. There are three time constants, 10, 30 and 60 seconds. This is the time the instrument will gather data before presenting it on the screen. The upper right hand corner of the rate display will show the time remaining in this time constant, i.e. before updating. The instrument will remember the time constant when it is turned off. The next time it is

turned on it will have the same time constant. If it is set to 60 seconds and turned off, the next time it is turned on it will still be 60 seconds.

LEVEL 2 ↓**DISPL** Changes the contrast of the display. There are 12 levels of contrast. Each push of the ↓**DISPL** button will change the contrast by one level. When the contrast reaches the maximum it jumps to the minimum. Just keep pushing the button until the contrast looks correct. When the instrument is turned off, it remembers the contrast setting.

LEVEL 2 ↓**NEXT** Changes from level 2 to level 3

*NOTE: To reach LEVEL 3 from normal operation push **MODE**, ↓**NEXT**, ↓**NEXT**.*

LEVEL 3 ↓**CHECK** Turns on the check source and checks for the peak channel number from this operation. See section on Check.

LEVEL 3 ↓**NEXT** Changes from level 3 to normal operation.

*NOTE: To reach Check from normal operation push **MODE**, ↓**NEXT**, ↓**NEXT**, ↓**CHECK**.*

CHECK ↓**NEXT** Changes to normal operation, same as level 3 ↓**NEXT**.

*NOTE: To reach MCA from normal operation push **MODE**, ↓**NEXT**, ↓**NEXT**, ↓**MCA**.*

MCA ↓**NEXT** Changes to normal operation, same as level 3 ↓**NEXT**.

VI. OVERFLOW, AND HIGH RADIATION LEVELS

High level radiation (over 100 REM/h or 10 RAD/h) may give poor results. This depends on the average quality factor of the radiation. The instrument does not have any dead time correction and consequently, while the software is capable of going up to 999 REM/h, the detector and electronics may not be. The dead time associated with each pulse is about 60 μS. The instrument works by acquiring each pulse, measuring its height, and then adding one to one of the 256 channels that correspond to its height. It is a classic multichannel analyzer. Every 10 seconds the instrument calculates the raw REM and RAD data and resets all 256 channels to zero and starts acquiring the data again.

There are several problems with this approach. The first is that each channel can only store 65536 counts. The second is that the higher channels contribute much more to the radiation level than do the lower channels, because of their higher quality factor. Channel 10 has a quality factor of 3.2, while channel 230 has a quality factor of 24.8. The RAD ranges have no quality factor. These three items,

dead time, maximum counts/channel, and different quality factors lead us to several guidelines:

1. At 10,000 counts in 10 seconds, the instrument will lose 1% of the counts and response will start to fall off above this amount.
3. If the REM/h range is overrange, then suspect the RAD/h range has dead time losses.
4. If you have to use the instrument in high radiation levels, then correct for dead time losses.

VII. SHOCK

The instrument has some sensitivity to shock. Banging the case or the detector could result in spurious counts. A sharp rap on the detector with a pencil will indeed produce spurious counts. Just hold the instrument with the handle and don't bang it against anything while making measurements.

VIII. LOW BATTERY

When first turned on the instrument turns on the light and checks the status of the battery. If it has less than 10 hours remaining, it will show LOW BATTERY in the display. If the batteries are too poor to turn the instrument on the display will remain dim.

During normal operation the instrument continually checks the status of the batteries. If it sees that there are only 10 hours remaining, then the instrument will flash LBAT in the upper right hand corner of the display every 13 seconds. This is only in the RATE and INTEGRATE modes, it will not show low battery in LEVEL 1, 2, 3 or CHECK. In the MCA mode the upper right corner will flash when the batteries are low.

The light uses the most power. If the batteries just check good, turning on the light may make them check bad. This is the reason the instrument, when first turned on, checks the batteries with the light on. When the batteries are low it is a good idea not to use the light.

IX. BATTERY REPLACEMENT

The Rem 500 uses 6 C cells, either carbon zinc or alkaline. The alkaline will of course last longer. The current drain is less than 40 mA with the light off.

To change the batteries remove the four screws on the end of the case that hold on the small cover. The batteries should fall out. Use the sticker on the inside of the

box as a guideline for inserting them. The batteries on the left hand side go in caps first, and those on the right go in with their caps out. Do not ship the instrument with batteries because it may turn on in shipment.

X. FAILURE

The instrument self checks itself at turn on. If it detects a failure it will display FAILURE in the display. If this occurs the instrument cannot be used. See the Maintenance Mode section for repair procedures.

XI. STATISTICS AND COUNTS

The display shows the number of counts that the instrument has received for that reading in the lower right hand corner. For valid statistics the number of counts is important. To achieve a reasonable accurate reading the number of counts needs to be at least 10. It should preferably be around 100 and for more accurate analysis it should be around 1000. This is the reason for the different time constants. In high radiation areas the time constant may be any setting but the lower TC of 10 sec would probably be sufficient if the counts are high enough. Obviously as the radiation level decreases the time constant should be increased to 30 or 60 seconds to give more time to accumulate counts to obtain better statistics. The integrate range can be used for any radiation level but it is really ideal when looking at very low levels.

XII. CHECK MODE

The Check mode of operation is used to determine the quality of the detector, and to check the operation of the instrument. It can be used as an operational check. To get in to the Check mode from normal operation push **MODE**, **↓NEXT**, **↓NEXT**, **↓CHECK**.

LFT	PK	RT	NEXT
080	090	100	↓

Inside the detector is a small Curium alpha source. When in the Check mode the curium source radiates a small stream of alphas across the center of the detector. These events simulate a neutron event in channel 90 of the instrument.

In the Check mode, the instrument operates as a multichannel analyzer and displays the peak (PK) channel number as well as the left (LFT) and right (RT) half max channel numbers. It updates the display every second. Pushing the **ALT** button will reset the MCA data and restart the acquisition. If the display remains on channel 0 or 1 this indicates that the instrument is not functioning properly. Try tapping on the side of the detector to free the shutter that shields the alpha source.

The peak channel indicates the calibration of the instrument, and the left and right half max channels indicate the quality of the detector. The peak should be within

15 channels of 90. Each channel away from 90 is an error of about 1.5% if the Calibration Factor remains unchanged. If it is out of this range, then the high voltage needs to be adjusted as described in the Calibration Mode section VI. The spread of the channels (RIGHT-LEFT) should be no more than 50 channels. If the spread is more than this then the detector needs to be returned to the factory for refilling.

Leave this mode by pushing ↓NEXT. If the rate display reads a high number after leaving Check mode, then the magnet actuated shutter that shields the alpha source may be stuck. Just tapping the side of the detector should free the shutter.

There is also an additional Check mode in the Multichannel Analyzer section that allows dumping all the channels. See that section for a description of the Check mode.

XIII. MULTICHANNEL ANALYZER MODE

This mode is only available if the MCA option has been installed. Figure 3 shows the Multichannel Analyzer (MCA) display. The MCA mode can be reached by pushing **MODE** ↓NEXT ↓NEXT ↓MCA from the Rate display. This display is continually updated. The upper left shows the time that the MCA has been running. It displays the time in HRS:MIN:SEC and will go as high as 18 hrs, 12 min,



Figure 3 MCA is stopped. Right button is marked RUN.

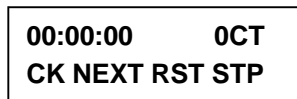

MCA is running. Note how right button has changed to STP

15 seconds before it rolls over to zero and continues to count up again. The upper right corner shows the number of events that have been counted the same as in the integrate range. The buttons are relabeled with the names shown in the display. The abbreviations are: ↓CK stands for CHECK and turns on and off the source inside the detector. Push it once to turn on the source. Push it again and the source will turn off. If the MCA is not running then there is no visual indication that the source is on or off. ↓NEXT will return to normal rate display. RST Resets the MCA by clearing all the channels, time and counts. ↓RUN and ↓STP are the same button. When the MCA is stopped the button says ↓RUN indicating that pushing it will start it running. If the MCA is running, the button says ↓STP indicating that pushing it will stop it.

All of these operations are duplicated in the RS-232 serial link. See the following section on SERIAL COMMUNICATIONS section for more details on this link.

XIV. SERIAL COMMUNICATIONS

There is an RS-232 Serial link built into the REM-500 for communications with a terminal or computer. It is only available if the MCA mode is installed. The link not only allows the user remote control of the MCA but also dumps the data on command. One end of the RS-232 Cable plugs into the top of the REM-500 next to the handle. The other end plugs into the 25 pin RS-232 COM port of a Personal Computer or a terminal. The computer or terminal should be set to: 9600 baud, no parity, 8 data bits, 1 stop bit. The serial link allows communications with both the normal rate and integrate displays and with the MCA. When the instrument is in the normal rate or integrate mode sending a **T** to the REM-500 will turn on the data link. The instrument will respond with an * and will send out the radiation level every time it updates the display. The level is the same as the display. This is every 10 seconds in the integrate mode, and when the time reaches 0 in the rate display. To turn it off, turn the instrument off. The data that is transmitted is 5 digits of radiation level followed by an exponent. The basic units are uREM, uRAD, uREM/h and uRAD/h or nSv, nGy, nSv/h and nGy/h depending on the mode the instrument is in and are the same as the display. The exponent is the power of 10 that the reading should be multiplied by. Thus 12567 0 would be $12567 \times 10E0$ which is 12567 uREM/h or 12.567 mREM/h and 67785 3 would be $67785 \times 10E3$ which is 67785×1000 which is 67785000 uREM/h which is 67.785 REM/h if the instrument was in the rate mode reading REM.

In the MCA mode the serial link allows complete control of the MCA. The instrument must be in the MCA mode for this link to function. The commands are single characters except for the **D** command and are as follows:

- R** RESET This will reset the MCA and all data, time and channels. This is the same as pushing the RST button.
- S** STOP This will stop the MCA. This is the same as pushing the STP button.
- G** GO This will start the MCA. This is the same as pushing the RUN button.
- C** CHECK This will turn on the check source in the detector if the source is off, and turn it off if it is on. This is the same as pushing the CK button.
- D** This will dump the channel data on the serial port. A character is needed after the D to actually send the data, i.e. it needs two characters to dump the data, a D followed by any character. The instrument automatically stops before dumping the data.

In addition, when the instrument is running in MCA mode, it will send the following line every second: 6 hex digits of counts followed by the time in HR:MIN:SEC. These values are the same values as shown on the display except the counts are in hex.

DATA DUMP OF CHANNELS

Sending a D followed by another character when the instrument is in the MCA mode will dump the data from the channels. The Data record is as follows:

256 lines of 5 digits. This is the counts for each channel. The counts are from 0 to 65534. 65535 is the maximum count even if the counts are more than this. There is no overflow indication other than keeping the count at the maximum value. The next is a line of counts and time. The counts are in HEX and are the total counts of all channels. This is 6 hex digits. The time is in HR:MIN:SEC. This line is the same as sent every second when the MCA is running.

XV. PRINCIPAL OF OPERATION

The Instrument is basically a 256 channel multichannel analyzer or MCA with a dedicated program coupled to a Tissue Equivalent Rossi type spherical proportional counter.

1. ELECTRONICS/SOFTWARE

In normal operation the instrument gathers the pulses from the detector, measures their height, counts them and stores them according to their height, and then calculates the correct REM or RAD. Every 10 seconds it goes through this routine, and every 10 second interval is separate. In the rate mode it uses 1, 3, or 6 (depending on the TC) of these 10 second intervals for the total value. In the integrate mode it just sums the results of each 10 second calculation. Thus every 10 second operation is the same regardless of the mode or the time constant.

The display is derived from the formulas:

For a 10 second integration period, where TC = 1 for 10 sec, 3 to 30 sec, 6 for 60 sec and 360 for integrate.

$$REM = K \sum_5^{255} \times \frac{CHAN \# \times CNTS \text{ per chan} \times QF}{TC \times 25.6}$$

$$RAD = K \sum_5^{255} \times \frac{CHAN \# \times CNTS \text{ per chan}}{TC \times 25.6}$$

The QF for the channels is derived from a smoothing of the ICRP values and ranges from 1 to 24.8. K is the Calibration Factor. If you wish a different QF then please consult HPI. The RAD display is thus the same as the REM except for the Quality factors. The average quality factor can be derived by dividing the REM reading by the RAD reading.

2. DETECTOR

The detector is a spherical tissue equivalent proportional counter which measures the absorbed dose in LET (actually P[Y]) spectra. It is based upon the design originated by Rossi using a spiral grid over the electrode for uniform collection characteristics.

The detector is housed in an aluminum shell which serves as a vacuum tight housing. The housing is filled with propane gas which allows the spherical detector to simulate small tissue volumes of approximately 2 micron diameter.

An internal Cm^{244} alpha source is mounted to allow the alpha particles to traverse the diameter of the sphere in the CHECK mode. The energy deposited by the alpha particle is considered to be $90 \text{ KeV}/\mu$. Therefore by adjusting the system to place the peak into channel 90, the pulse height of the interactions will correspond to the energy deposition in KeV/μ .

When the instrument is placed in a neutron field, the interactions with the neutrons will cause a recoil proton to traverse a portion of the sphere. The neutron collides with a nucleus and is scattered with a loss of energy which appears as the kinetic energy of the recoil nucleus. In tissue, elastic scattering is the dominant neutron interaction in the energy interval 10 KeV to 10 MeV i.e. the sum of the kinetic energies of the participating particles remains constant before and after the interaction. The average neutron energy loss will be one half for a collision with a hydrogen atom.

In interactions of neutrons with energies below 10 KeV, a recoil proton in tissue no longer has sufficient velocity to ionize matter and will not be efficiently detected. The lowest detection level for the instrument is set at channel 5. Pulses below this value are considered to be gamma ray interactions or spurious noise pulses.

For neutrons with energies above 10 MeV inelastic scattering and nuclear interactions become important. For these high energy events the spherical detector reproduces the energy losses that would occur in a single tissue cell from such high energy interactions.

LET distributions from neutron fields interacting with tissue have been studied extensively. Proton recoils from neutrons of energy 10 KeV to 1 MeV have a maximum LET of about $85\text{-}90 \text{ KeV}/\mu$. This maximum LET occurs near the peak of the Bragg Curve. The LET of proton recoils from neutrons with energies above 1 MeV gradually decreased in such a manner that at a neutron energy of 20 MeV the LET has decreased to $5 \text{ KeV}/\mu$.

Carbon atom recoils from neutron interactions show an increasing LET with increasing neutron energy such that with incident neutron energy of 20 MeV a carbon recoil will exhibit an LET of over $400 \text{ KeV}/\mu$.

The detector measures the LET from all neutron interactions that are important for radiobiological studies. ICRP has developed radiation protection standards to evaluate the quality factors which are applied to the pulse heights produced in the detector and processed by the associated electronics.

XVI. CALIBRATION MODE

The Calibration Mode is used to change the overall sensitivity of the instrument, change it to SI units, and to adjust the high voltage. It was setup and calibrated at the factory but can be easily changed. The Calibration mode lets you change the Calibration Factor which changes all readings the same; integrate and rate, REM and RAD, and it also lets you change the high voltage which increases or decreases the channel number of the peak in the check mode.

Getting into the Calibration Mode can be accomplished two ways: Method 1 is to

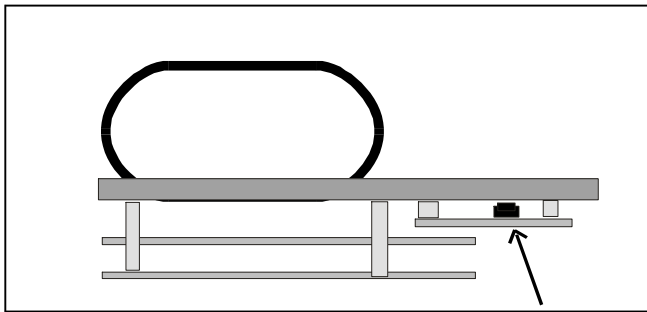

LOCATION OF CAL PUSHBUTTON

The Cal Pushbutton is located on the right hand side of the instrument on the display board. To access it, remove the four screws on the top plate. Be careful of the wires. The Pushbutton is pushed from above.

turn the instrument off then push down the cal pushbutton inside the instrument (located on the display circuit board) and hold it down while turning on the instrument. The Calibrate Mode will be immediately visible showing the High Voltage Adjust display as shown below. Method 2 is to turn the instrument off. Hold down the **ALT** button and turn the instrument on. Keep holding the **ALT** button down, letting it go even for a microsecond will enter normal operation. In 10 seconds the Calibrate Mode will be displayed. If this does not work, then the instrument has been programmed to not enter the Calibrate Mode from the front panel and it

will be necessary to open the case and enter the mode by method 1.

PK:090 HF:130
UP DN SAVE RST

This is the first display of the Calibrate Mode and is the High Voltage Adjust display. Although the display does not show any down arrows indicating the keys, they are assumed to be there .

The first display is the High Voltage Adjust display. This display allows you to change the high voltage which changes the peak. If the peak is below 90, then raising the high voltage will raise the peak. Likewise if the peak is above 90, lowering the high voltage will lower the peak. The top line shows the peak (PK), followed by the High Voltage Factor (HVF). The High Voltage Factor is proportional to the high voltage. It is displayed instead of the actual high voltage. Raising it will raise the high voltage and conversely lowering it will lower the high voltage.

In this mode all of the buttons except the **ON/OFF** button are redefined. The **MODE** button becomes the **↓UP** and the **ALT** button becomes the **↓DN**. They work by raising and lowering the high voltage factor which raises and lowers the high voltage. To increase the high voltage factor, push and hold down

the **↓UP** button. The High Voltage Factor will increase by 1 every second. The **↓DN** button works in the same way except that it lowers the High Voltage Factor. To raise the factor by 10 it is necessary to hold down the **↓UP** button for about 10 seconds.

The **RESET** button becomes the **↓SAVE** button and will put the new High Voltage Factor into the permanent memory of the instrument, and then go to the Calibration Factor display. Until this button is pushed, the High Voltage Factor is not changed inside the instrument. Turning the instrument off and on will restore the original value. After setting the High Voltage Factor to the correct value in the display push **↓SAVE**. The **LIGHT** button becomes the **↓RST** button or reset button. This resets the peak values and starts the peak calculations all over again. For the proper setting of this adjustment, see the following section on Calibration.

The Calibration Factor display is the next display. The number in the upper left hand is the Calibration Factor. It is the number that needs to be changed to increase or decrease the sensitivity of the instrument. It's nominal value is 100 but it is adjusted differently for each instrument.

<p>100 CALIBRATE UP DN SAVE P</p>

CALIBRATE FACTOR display is for changing the overall calibration.

In this mode all of the buttons except the **ON/OFF** button are redefined. The **MODE** button becomes the **↓UP** and the **ALT** button becomes the **↓DN**. They work by raising and lowering the Calibration Factor. Each time the **↓UP** is pushed it raises the factor by 1. Each time the **↓DN** is pushed it lowers the factor by 1. Holding the buttons down will do nothing. To raise the factor by 10 it is necessary to push the **↓UP** button 10 times.

The **RESET** button becomes the **↓SAVE** button and will put the new Calibration Factor into the permanent memory of the instrument, and then go to the Calibration Select display. Until this button is pushed, the calibration factor is not changed inside the instrument. Turning the instrument off and on will restore the original value. After setting the calibration factor to the correct value in the display push **↓SAVE**. The **LIGHT** button becomes the **↓UP** button or Preset button. This presets all the permanent values into the instrument. It sets the Calibration factor to 100, the time constant to 10 seconds, the display to the middle of its contrast range, the high voltage to its nominal value, and the Calibration Select to ON, enabling the front panel calibrate button. Push it to set all these values to these levels.

CALIBRATE SELECT

The next menu that will appear after pushing **↓SAVE** is the Calibrate Select display. The top line will tell you the current status of the instrument. If it displays Front Panel On it means that you will be able to get into the Calibrate Mode from the front panel. Front Panel Off means that you must open the enclosure to get into the Calibrate Mode. Pushing the **↓ON** or **↓OFF** button will change the status of the Calibrate Select. You can see the change on the first line. Pushing **↓SAVE** will save this and return to normal operation

<p>FRONT PANEL ON ON OFF SAVE</p>

CALIBRATE SELECT turns the front panel calibration button on and off.

To summarize: If you want the convenience of getting into the calibrate mode without opening the case and are not concerned with security of the calibrate number then push ↓**YES** and then ↓**SAVE**. If you do not want anyone to be able to enter the calibrate mode without having to open the case then push ↓**OFF** and ↓**SAVE**.

SI UNITS SELECT

SELECT UNITS SI REM OK

SI UNITS SELECT chooses the units for the displays. Rad/Rem or Sv/Gy are the choices.

The next menu that will appear after pushing the calibrate select is the SI Units Select display. The choice is either for SI units or REM/RAD units. This will effect the units in the rate and integrate displays and in the download data. Pushing ↓**SI** will put the instrument in the SI Units mode. Pushing the ↓**REM** will put the instrument in the Rem/Rad units mode. Pushing the ↓**OK** will result in no change.

XVII. CALIBRATING THE INSTRUMENT

The instrument is easily calibrated. There are two stages to the calibration. The first is to adjust the high voltage so the channel numbers correspond to known energies. The second stage is to expose the instrument to a calibrated neutron source to set the overall sensitivity of the instrument.

REQUIRED: Calibrated neutron source

Both stages use the calibrate mode. Please read the previous section on how to enter in the calibrate mode. The first stage of the calibration is the adjustment of the high voltage. This is accomplished by:

1. Enter the Calibrate mode. You will be in the High Voltage Adjust display. (See section XVI. for instructions on how to enter the Calibrate Mode.)
2. Wait about 15 to 30 seconds for the high voltage to stabilize.
3. Push the **↓RST** button to restart the peak calculations.
4. Wait 30 seconds to 1 minute for the peak to stabilize.
5. We want the peak to be in channel 90. If it is not in channel 90 then it is necessary to change the high voltage. If the peak is below channel 90 then it is necessary to raise the high voltage, and if it is above channel 90 it is necessary to lower the high voltage. You should set it to channel 90 ± 3 channels. Raising the High Voltage Factor by 1 will raise the peak about 1/2 channel.

Repeat steps 2, 3, 4, and 5 over until the peak is on channel 90 ± 3 channels. When you are satisfied with the reading, push the **SAVE** button. This will save the values and change the display to the Calibrate Adjust display. Exit the calibration displays by pushing **↓SAVE**, **↓SAVE** and **↓OK**.

This completes the high voltage adjustment stage. The next stage is to check and if necessary adjust the overall sensitivity of the instrument.

1. Using the calibrated neutron source, expose the instrument to a known quantity of radiation. It is desirable to expose it in the integrate range for a period of time sufficient to accumulate at least 1000 counts.
2. Calculate the correction factor for the instrument.

CORRECTION FACTOR = DESIRED LEVEL / READING

3. Enter the Calibration Mode. See the Calibration Mode section for a description of how to get into this mode. Bypass the High Voltage Adjust display by pushing **SAVE**. You are now in the Calibration Adjust display.

4. Multiply the Calibration Factor in the display by the correction factor to obtain a new Calibration Factor.
5. Set the new calibration factor in the instrument by using the ↓**UP** and ↓**DN** buttons. When the value is correct, push the ↓**SAVE** button. Exit the Calibration mode by pushing ↓**SAVE** and ↓**OK**.
6. Repeat step 1 to 5 until the instrument reads correctly.

Steps 2 to 5 correct the instrument Calibration Factor to match the reading i.e. if the reading is 10% low then you need to raise the correction factor by 10%.

XVIII. RADIOACTIVE MATERIAL INSIDE DETECTOR

The sealed detector contains a 1 microcurie \pm 20% Curium 244 check source. The source material is deposited on the end of a .063 dia stainless steel rod and has a gold flashing over it to secure the source material. It is necessary for you to include this source material on your radioactive materials license.

If it is necessary to ship the instrument it should have a statement as to the type of radioactive material (Cm^{244}) and the amount (1 microcurie). It should also include the following statement in the box so it is the first thing seen when the box is opened. No special packaging material is required other than the normal 2" packing material on all sides and a sturdy cardboard box.

FROM: _____

ADDRESS: _____

This package conforms to the conditions and limitations specified in 49 CFR 173.421 for Excepted Radioactive Material, Limited Quantities, N.O.S., UN 2910 and also IATA section 5.7.27.

This is to certify that this package conforms to all packaging requirements of the U.S. Department of Transportation and the International Aid Transport Association rules and regulations regarding the shipment of Radioactive Materials, Limited Quantities.

The radiation level on the surface of this package is less than 0.5 mR/hr. No other labels required.

NAME: _____

SIGNATURE: _____

TITLE: _____

The above form serves only as a guideline. Your requirements may change depending on government regulations.

XIX. MAINTENANCE MODE

090	000	L3
MAG	ADC	CLR

MAINTENANCE MODE

Maintenance Mode is used for electronic checkout. To get into Maintenance Mode Hold down the **MODE** and **RESET** keys while turning the instrument on. If the instrument has failed see below. In the Maintenance Mode the 3 digits in the upper left of the display are the channel number of the pulse height. This ranges from 000 to 255. The next three digits are the contents of the pulse counter. Every time a new count is received the counter increments by one. The next item is either the letter H or L. This is the comparator that checks the condition of the battery. If it is L it indicates a good battery, if it is H it indicates a bad battery. The Last item is the number of the last switch that was pushed. The switch numbers are: 1, **MODE**; 2, **ALT**; 3, **RESET**; 4, **LIGHT**; and 5, **CAL** button.

The buttons are redefined and their abbreviations are show on line 2. The **MODE** button becomes the ↓**MAG** or MAGNET button. The **ALT** button becomes the ↓**ADC** button. The **RESET** button is the ↓**CLR** or CLEAR button, and the **LIGHT** button remains the LIGHT button. The action of each of these buttons is defined below.

↓**MAG** Turns on the Magnet attached to the outside of the detector. This causes the internal alpha source to irradiate the detector simulating neutron events with an average energy that should be in channel 90. The electronics can be tested with these signals. The Display should also show the counts, although the peak energy is hard to see because of the number of counts. Turn the magnet off by pushing ↓**CLR**.

↓**ADC** After it is pushed the software constantly resets the ADC portion of the circuit. It puts a constant pulse on pin 2 U4 and on pin 13 U3A and on pin 10 U6B. Turn it off by pushing ↓**CLR**.

↓**CLR** This button clears all the parameters set by the other buttons. It turns on the interrupts and the timer. It turns off the magnet, the ADC reset signal and the beeper.

LIGHT The light is turned on whenever this button is pushed and turned off by pushing ↓**CLR**. This button sends an 'H' out the serial port if the serial port is installed. It also turns off the interrupt and timer.

CAL This turns on the beeper. Pushing ↓**CLR** turns it off.

If the EEPROM has failed the instrument will display a dim FAILURE. If this is the case then it is necessary to replace the EEPROM (U16 on the Digital Board). After replacing it enter the Maintenance Mode and push LIGHT at the failure indication. This will program the EEPROM with default values. Then turn the instrument on and off again to resume normal operation. The instrument will need to be recalibrated because the Calibration Factor is in the EEPROM.

XX. CIRCUIT DESCRIPTION

The electronic circuit is broken down into two main sections; the analog and the digital circuits. Each circuit has two printed circuit boards associated with it.

DIGITAL CIRCUIT

The digital circuit comprises the Digital Circuit Board and the Display Board. Both are shown on schematic # REM1-002.

POWER SUPPLY

The instrument is powered by 6 C cells. The negative side of the batteries is switched to turn the instrument on and off. U13 forms an alternate action set-reset flip-flop that is controlled by the front panel on-off switch. The output of this flip-flop turns on Q5 which grounds the negative side of the battery to turn the instrument on. U13 is always powered on but its current drain when the instrument is off is only a couple of microamps.

The battery power goes to a 3 terminal regulator, U14 which has a low drop out voltage. Its output is + 5V. U17 and U18 form a voltage converter that changes the + 5V into - 5V, + 8V, and - 8V. U12B is a low battery detector used to reset the system when the battery voltage drops too low. When the battery voltage gets to 5.4V it puts the system into reset. This causes the display to go dim because the NSC810 outputs turn into inputs and the contrast is changed. The other half of U12, U12A, is the low battery detector. It switches at about 6V.

MICROPROCESSOR

The microprocessor, U1 is an NSC800 and uses the Z80 instruction set. It is supported by the address latch U2, EPROM U3, RAM U4, address decoder U10 and various other gates, U7, U8, U9, and U11. The oscillator X1, R2, C2, and C3 oscillates at 4.0 MHz. It is the timebase for the instrument.

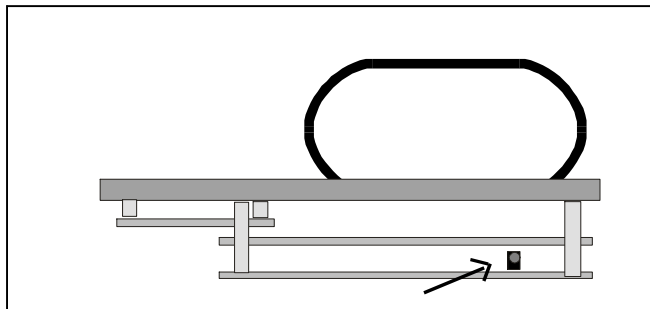

LOCATION OF HIGH VOLTAGE CONTROL

The High Voltage Control is located on the left hand side of the instrument on the analog board. To access it remove the four screws on the top plate. Be careful of the wires. Turning the control clockwise raises the peak, turning it counter-clockwise lowers it.

ADC CONTROL

The ADC is memory mapped just like all the other peripherals. Reading it activates the output of U9C and this controls the signal ADC RESET. This is the only signal that resets the ADC.

When a conversion is ready, it signals the system through the INTR line.

IN/OUT

The In/Out ports for the system are in the NSC810, U15. This chip has an I/O, a RAM and a timer. The RAM is used for the stack, the timer is used to generate the 1 second heartbeat from T0 out. This goes to the NMI input on the microprocessor. The various ports are used as follows:

PA0, Pin 21 controls the electromagnet, L1, on the side of the detector. To turn on L1, Pin 21 U15 goes high. This turns on the gate of Q2. Q2 brings the P2:4 end of L1 to ground turning it on. The other side of L1 goes to unregulated battery voltage, VBAT.

PA1, Pin 22 controls the buzzer in the same way that the electromagnet is controlled.

PA2, Pin 23 controls the front panel backlight. To turn on the light Pin 23 U15 goes high (It is normally low). This turns off Q4 whose LCDLED end now goes toward VBAT because of pullup resistor R14. This turns on Q1 on the display board which turns on the LCD lamp.

PA3, Pin 24, and **PA4** Pin 25, are not used and are pulled up using RN2.

PA5, Pin 26 controls the CS or Chip select input on the EEPROM.

PA6, Pin 27 controls the SK or clock input on the EEPROM.

PA7, Pin 28 controls the DI or Data Input line of the EEPROM.

PB0, Pin 29 receives the DO or Data Output line from the EEPROM.

PB1, Pin 30 is the input from the CAL switch on the front panel.

PB2, Pin 31 is the input from the low battery detector U12A.

PB3, Pin 32 is the input from the LIGHT switch on the front panel.

PB4, Pin 33 is the input from the RESET switch on the front panel.

PB5, Pin 34 is the input from the ALT switch on the front panel.

PB6, Pin 35 is the input from the MODE switch on the front panel.

All the switches are normally high because of pullup resistor network RN2.

The four pushbuttons, S3, 4, 5, & 6 are all also connected to D3, 4, 5, & 6. When any of the pushbuttons are pushed, it grounds RSTC, through the diode. RSTC is an interrupt input to the microprocessor.

PC0, Pin 37 is the LSB of the R-2R ladder network used to generate the voltages for the LCD contrast.

PC1, Pin 38 is bit 1 of the R-2R ladder network used to generate the voltages for the LCD contrast.

PC2, Pin 39 is bit 2 of the R-2R ladder network used to generate the voltages for the LCD contrast.

PC3, Pin 1 is the MSB of the R-2R ladder network used to generate the voltages for the LCD contrast.

PC4, Pin 2 and **PC5**, Pin 5 are not used and are pulled up by RN2.

DISPLAY

The LCD display is U6. It has a contrast input that is controlled by U5 and the R-2R ladder network U7 thru R13. This is the digital control of the contrast. R5 is the coarse set for the contrast.

EEPROM

The EEPROM holds 128 bytes of data even when the power is off. Only 7 bytes are used.

SERIAL PORT

U19 and U20 comprise the serial port. U19 is the UART and U20 is the voltage drivers for RS-232. The UART has its own crystal, X2.

ANALOG CIRCUIT

The analog circuit is on two circuit boards, the Preamp and the Analog Circuit Board. They are shown in schematic # REM1-001.

HIGH VOLTAGE POWER SUPPLY

The supply output, for the detector, is around 500V. U9A is an oscillator which produces a 2 usec pulse every .4 msec. This drives U9B which expands the pulse width and turns it on and off depending on the output of U10. The output of U9 drives Q5 which in turn drives T1. This is a step up transformer. Its secondary is rectified by D5 and filtered by R46, C31 and in the preamp by C4, C3, and R5. The high voltage is measured by resistor divider R47 and R48 and R49. U10 compares this voltage to that set by R51, the high voltage control and the DAC, and turns on and off the oscillator in U9B to regulate the voltage. R4, and R2 are a voltage divider to provide the helix in the detector with the correct voltage. The DAC allows the high voltage to be adjusted by the front panel and consists of the

ladder network, R56 to R71. The shift register U11 shifts and latches the serial data from the microprocessor to the ladder network

PREAMP

The high gain charge sensitive preamp uses a low noise 2N4416 as the input FET. Q2 provides bias for Q1. Q3 is an impedance converter and Q4 is the output buffer. Feedback is by R15 and the small amount of stray capacitance across it is the feedback capacitor. The output of the preamp is a series of ramps. The input pulse drives the output positive, and then the signal slowly decays back toward ground. TP1 is an input for an external pulsar.

POST AMPLIFIERS

R17 is the pole zero control. U1's four amplifiers shape the pulses for use by the ADC. **R28x sets the gain.**

MCA

U5, a voltage comparator, and U6 a flip flop start the ADC conversion. U5A detects the peak above the Low Level Discriminator (LLD). The signal then is amplified by U2A and U2B. They form a closed loop to charge capacitor C22 to the peak value of the input pulse. The output of U2A drives the input of the Analog to Digital Converter, U4. U7 times the conversion. U3A and U3D reset the peak catcher. The reference voltage of 2.5V for the ADC is set by U8. R32 sets the Low Level Discriminator, below which the pulses will not initiate a conversion. The microprocessor after processing the signal, resets the ADC by J4:10.

XXI. ELECTRONIC ADJUSTMENTS

There are 4 electronic adjustments. All controls are independent and do not need to be done in any order; they were factory set and do not usually need adjustment. Replacing the detector would necessitate adjusting the Pole Zero, the high voltage and doing a calibration.

HIGH VOLTAGE

The High Voltage control is on the bottom right of the Analog Circuit Board. Set the High Voltage Factor in the High Voltage Adjust display of the Calibrate mode to 130. Exit the Calibrate mode. Enter the Check mode and look at the peak under the Check Mode. Adjust the high voltage until the peak is on channel 90 ± 2 channels.

CONTRAST

The Coarse Contrast control on the lower right hand side of the Digital Board adjusts the contrast of the display. The Contrast adjust from the front panel fine tunes this value. To set the pot:

1. Turn the instrument on, press MODE then ↓**NEXT** to get into the display change mode. Push the ↓**DISPL** button 20 times. The contrast will get dark, then jump to light and get dark again. There are 12 steps in the adjustment, and every time the ↓**DISPL** pushbutton is pushed it changes the level 1 step.
2. Adjust the Coarse Contrast control until it seems that the 12 steps are in the middle of the range of the display. The lightest display should be just visible.

LLD

The LLD, on the upper left of the Analog Board, is set with a voltmeter.

1. Attach a voltmeter negative lead to Test Point TP5. Attach the positive lead to Test Point TP3. Adjust the LLD SET control until the voltmeter reads 158 millivolts.
2. This adjustment can be checked with a mercury pulsar connected between TP1 and ground, TP5. Enter maintenance mode and adjust the pulsar to channel 10. Then slowly lower the pulsar and note the lowest channel that is displayed on the left of the display. Raise the level back to around channel 10 and slowly lower it again. Do this a couple of times to check the lowest channel number. It should be channel 5. If it is a higher number then lower the LLD slightly and try it again.

POLE ZERO

The Pole Zero is on the upper left of the Analog Board. Connect an oscilloscope between ground, TP5 and pin 1 of U1. Enter the Maintenance Mode and turn on the magnet. Adjust the Pole Zero control fully CCW. Then adjust the control until the bottom of each pulse is even with the baseline of all the pulses.

XXII. TROUBLE SHOOTING NOTES

1. A mercury pulsar can be used to test the instrument. It connects to TP1 and ground (TP5) on the Analog Board.
2. Pressing the CAL button on the front panel after the unit is turned on will terminate the 15 second self check at power up. This is useful for testing the instrument especially if you have to turn it on and off many times.
3. If the instrument does not work, and there is power to the chips, then turn the instrument off short pin 1 and 2 of the NSC810 and turn power back on. This will cause the program to send out a pulse train on pin 1 of the NSC810. If this occurs, then the microprocessor is working. You can disconnect the following to see if it works: U5 LCD display, U4-RAM, U19-UART, U20, U16, U12, U5, U11, and U8. The pulse does not need any of these. If they are removed and it works, then try putting them in and see if the pulses are still there.
4. If there is no display then try changing the contrast. It may be that the contrast is too light. The coarse contrast may also need changing.
5. The two circuit boards hinge on one side. Undo the two screws on the side opposite the hinges on each board and they will open like a fan.

XXIII. QUALITY FACTORS

Quality Factors for each channel as pre programmed into the REM-500 MCA VS1.0

QF = QF * 10 CHAN #	QF = QF * 10 CHAN #	QF = QF * 10 CHAN #	QF = QF * 10 CHAN #
QF = 4 ;1	QF = 147	QF = 225	QF = 248
QF = 7	QF = 149	QF = 226	QF = 248
QF = 11	QF = 151	QF = 226	QF = 248
QF = 14	QF = 152	QF = 228	QF = 248
QF = 17 ;5	QF = 153 ;70	QF = 228 ;135	QF = 248 ;200
QF = 20	QF = 156	QF = 229	QF = 248
QF = 25	QF = 157	QF = 229	QF = 248
QF = 27	QF = 158	QF = 230	QF = 248
QF = 30	QF = 160	QF = 230	QF = 248
QF = 32 ;10	QF = 162 ;75	QF = 231 ;140	QF = 248 ;205
QF = 35	QF = 163	QF = 233	QF = 248
QF = 37	QF = 165	QF = 233	QF = 248
QF = 40	QF = 166	QF = 234	QF = 248
QF = 42	QF = 168	QF = 234	QF = 248
QF = 45 ;15	QF = 170 ;80	QF = 235 ;145	QF = 248 ;210
QF = 47	QF = 171	QF = 235	QF = 248
QF = 50	QF = 172	QF = 236	QF = 248
QF = 52	QF = 173	QF = 236	QF = 248
QF = 54	QF = 174	QF = 238	QF = 248
QF = 57 ;20	QF = 176 ;85	QF = 238 ;150	QF = 248 ;215
QF = 58	QF = 177	QF = 238	QF = 248
QF = 61	QF = 178	QF = 239	QF = 248
QF = 62	QF = 179	QF = 239	QF = 248
QF = 64	QF = 182	QF = 240	QF = 248
QF = 67 ;25	QF = 183 ;90	QF = 240 ;155	QF = 248 ;220
QF = 69	QF = 184	QF = 240	QF = 248
QF = 72	QF = 186	QF = 241	QF = 248
QF = 73	QF = 187	QF = 241	QF = 248
QF = 75	QF = 188	QF = 243	QF = 248
QF = 78 ;30	QF = 189 ;95	QF = 243 ;160	QF = 248 ;225
QF = 80	QF = 191	QF = 243	QF = 248
QF = 82	QF = 192	QF = 244	QF = 248
QF = 84	QF = 193	QF = 244	QF = 248
QF = 87	QF = 194	QF = 244	QF = 248
QF = 88 ;35	QF = 196 ;100	QF = 245 ;165	QF = 248 ;230
QF = 90	QF = 197	QF = 245	QF = 248
QF = 93	QF = 198	QF = 245	QF = 248
QF = 94	QF = 199	QF = 246	QF = 248
QF = 97	QF = 200	QF = 246	QF = 248
QF = 99 ;40	QF = 202 ;105	QF = 246 ;170	QF = 248 ;235
QF = 100	QF = 202	QF = 246	QF = 248
QF = 103	QF = 203	QF = 248	QF = 248
QF = 105	QF = 204	QF = 248	QF = 248
QF = 106	QF = 205	QF = 248	QF = 248
QF = 109 ;45	QF = 207 ;110	QF = 248 ;175	QF = 248 ;240
QF = 110	QF = 208	QF = 248	QF = 248
QF = 113	QF = 208	QF = 248	QF = 248
QF = 114	QF = 209	QF = 248	QF = 248
QF = 116	QF = 210	QF = 248	QF = 248
QF = 118 ;50	QF = 212 ;115	QF = 248 ;180	QF = 248 ;245
QF = 120	QF = 212	QF = 248	QF = 248
QF = 121	QF = 213	QF = 248	QF = 248
QF = 124	QF = 214	QF = 248	QF = 248
QF = 126	QF = 215	QF = 248	QF = 248
QF = 127 ;55	QF = 215 ;120	QF = 248 ;185	QF = 248 ;250
QF = 129	QF = 217	QF = 248	QF = 248
QF = 131	QF = 218	QF = 248	QF = 248
QF = 132	QF = 219	QF = 248	QF = 248
QF = 135	QF = 219	QF = 248	QF = 248
QF = 136 ;60	QF = 220 ;125	QF = 248 ;190	QF = 248 ;255
QF = 139	QF = 222	QF = 248	QF = 248
QF = 140	QF = 222	QF = 248	QF = 248
QF = 142	QF = 223	QF = 248	QF = 248
QF = 144	QF = 224	QF = 248	QF = 248
QF = 145 ;65	QF = 224 ;130	QF = 248 ;195	QF = 248

XXIV. PARTS LIST

DESIGN	QUAN	PART NO	TYPE	DESCRIPTION	MFG	DRAWING #
C01	1	212-5315-47K	47 pF 600 VDC	Capacitor, film	Xicon	REM1-001
C02	1	581-33M16	33 uF 10 VDC	Capacitor, tant	Thomson	REM1-001
C03	1	EF6473	.047 600 VDC	Capacitor, film	Panasonic	REM1-001
C04	1	EF6473	.047 600 VDC	Capacitor, film	Panasonic	REM1-001
C05	1	232-1000-005	5 pF 50 VDC	Capacitor, slv mica		REM1-001
C06	1	581-33M10	33 uF 10 VDC	Capacitor, tant	Thomson	REM1-001
C07	1	581-33M10	33 uF 10 VDC	Capacitor, tant	Thomson	REM1-001
C08	1	581-10M10	10 uF 10VDC	Capacitor, tant	Thomson	REM1-001
C10	1	581-10M10	10 uF 10 VDC	Capacitor, tant	Thomson	REM1-001
C11	1	P3102	.001 uF 50 VDC	Capacitor, film	Panasonic	REM1-001
C12	1	P3103	.01 uF 50 VDC	Capacitor, film	Panasonic	REM1-001
C13	1	P3101	100 pF 50 VDC	Capacitor, film	Panasonic	REM1-001
C14	1	P3103	.01 uF 50 VDC	Capacitor, film	Panasonic	REM1-001
C15	1	P3101	100 pF 50 VDC	Capacitor, film	Panasonic	REM1-001
C16	1	P3104	.1 uF 50 VDC	Capacitor, film	Panasonic	REM1-001
C17	1	581-UDW104M1	.1 uF 50 VDC	Capacitor, mono	Thomson	REM1-001
C18	1	581-UDW104M1	.1 uF 50 VDC	Capacitor, mono	Thomson	REM1-001
C19	1	21RD722	22 pF 50 VDC	Capacitor, mono		REM1-001
C20	1	21RD710	10 pF 50 VDC	Capacitor, mono		REM1-001
C21	1	581-UEZ102K1	.001 uF 50 VDC	Capacitor, film	Thomson	REM1-001
C22	1	P3681	680 pF 50 VDC	Capacitor, film	Panasonic	REM1-001
C23	1	21RD610	100 pF 50 VDC	Capacitor, mono		REM1-001
C24	1	581-UEZ103K1	.01 uF 50 VDC	Capacitor, mono	Thomson	REM1-001
C25	1	581-UEZ102K1	.001 uF 50 VDC	Capacitor, mono	Thomson	REM1-001
C26	1	581-UEZ102K1	.001 uF 50 VDC	Capacitor, mono	Thomson	REM1-001
C27	1	21RD610	100 pF 50 VDC	Capacitor, mono		REM1-001
C28	1	581-47M16	47 uF 16 VDC	Capacitor, tant	Thomson	REM1-001
C29	1	581-UEZ102K1	.001 uF 50 VDC	Capacitor, mono	Thomson	REM1-001
C30	1	EF6103	.01 uF 600 VDC	Capacitor, film	Panasonic	REM1-001
C32	1	581-33M10	33 uF 10 VDC	Capacitor, film	Thomson	REM1-001
C33	1	581-UDW104M1	.1 uF 50 VDC	Capacitor, mono	Thomson	REM1-001
C34	1	581-UDW104M1	.1 uF 50 VDC	Capacitor, mono	Thomson	REM1-001
C35	1	581-UDW104M1	.1 uF 50 VDC	Capacitor, mono	Thomson	REM1-001
C36	1	581-UDW104M1	.1 uF 50 VDC	Capacitor, mono	Thomson	REM1-001
C37	1	581-UDW104M1	.1 uF 50 VDC	Capacitor, mono	Thomson	REM1-001
C38	1	581-UDW104M1	.1 uF 50 VDC	Capacitor, mono	Thomson	REM1-001
C39	1	581-33M10	33 uF 10 VDC	Capacitor, tant	Thomson	REM1-001
C40	1	581-UDW104M1	.1 uF 50 VDC	Capacitor, mono	Thomson	REM1-001
C41	1	581-UDW104M1	.1 uF 50 VDC	Capacitor, mono	Thomson	REM1-001
C42	1	581-33M10	33 uF 10 VDC	Capacitor, tant	Thomson	REM1-001
C43	1	581-10M10	10 uF 10 VDC	Capacitor, tant	Thomson	REM1-001
C44	1	581-10M10	10 uF 10 VDC	Capacitor, tant	Thomson	REM1-001
D1	1	1N4148PH	1N4148	Diode	Philips	REM1-001
D2	1	1N4148PH	1N4148	Diode	Philips	REM1-001
D3	1	1N5812	1N5812	Diode	HP	REM1-001
D4	1	1N5812	1N5812	Diode	HP	REM1-001
D5	1	FR107-ND	Fast Rec 1000 VDC	Diode	DI	REM1-001
J1	1	CHS10G-ND	10 Pin HDR .1x.1	Connector	CW Ind	REM1-001
J2	1	WML105	.093	Terminal	Molex	REM1-001
J3	1	WML105	.093	Terminal	Molex	REM1-001
J4	1	CHS26G-ND	26 Pin, MT, ST .1x.1	Connector	CW	REM1-001
P1	1	CHR10G-ND	10 Pin RA	Connector, MT .1x.1	CW Indust	REM1-001
Q1	1	2N4416A	2N4416	FET	GE	REM1-001
Q2	1	2N4416A	2N4416	FET	GE	REM1-001
Q3	1	PN4250	2N4450	Transistor	National	REM1-001
Q4	1	VN10KM	N PWR	FET	Siliconix	REM1-001
Q5	1	VN10KM	N PWR	FET	Siliconix	REM1-001
R01	1	MOX-300 1000M	1000M ohm 5%	Resistor	Victoreen	REM1-001
R02	1	MOX-300 250M	250M 5%	Resistor	Victoreen	REM1-001
R03	1	MOX-300 1000M	1000M ohm 5%	Resistor	Victoreen	REM1-001
R04	1	MOX-300 1000M	1000M 5%	Resistor	Victoreen	REM1-001
R05	2	299-10M	2 ea 10M 5% 1/8W	Resistor		REM1-001
R06	1	47.5X	47.5 1%	Resistor		REM1-001
R07	1	2.00KX	2.00K 1%	Resistor		REM1-001
R08	1	10.0KX	10K 1%	Resistor		REM1-001
R09	1	10.0KX	10K 1%	Resistor		REM1-001
R10	1	10.0X	10 ohm 1%	Resistor		REM1-001
R11	1	1.00MX	1.00M 1%	Resistor		REM1-001
R12	1	10.0KX	10K 1%	Resistor		REM1-001
R13	1	10Q	10 ohm 5%	Resistor		REM1-001
R14	1	10Q	10 ohm 5%	Resistor		REM1-001
R15	1	MOX-300 1000M	1000M 5%	Resistor	Victoreen	REM1-001
R16	1	CEG14	10 K	Pot, 3/8 top	Panasonic	REM1-001
R17	1	4.99KX	4.99K 1%	Resistor		REM1-001
R18	1	2.00KX	2.00K 1%	Resistor		REM1-001
R19	1	10.0KX	10 ohm 1%	Resistor		REM1-001
R20	1	100KX	100.0K ohm 1%	Resistor		REM1-001
R21	1	562X	562 1%	Resistor		REM1-001
R22	1	100KX	100.0K ohm 1%	Resistor		REM1-001
R23	1	100KX	100.0K ohm 1%	Resistor		REM1-001
R24	1	562X	562 1%	Resistor		REM1-001
R25	1	100KX	100.0K ohm 1%	Resistor		REM1-001
R26	1	100KX	100.0K ohm 1%	Resistor		REM1-001
R27	1	10KX	10K 1%	Resistor		REM1-001
R28	1	CEG15	100 K	Pot, 3/8 top	Panasonic	REM1-001
R29	1	51.1KX	51.1K 5%	Resistor		REM1-001
R30	1	100KX	100.0K ohm 1%	Resistor		REM1-001
R31	1	100KX	100.0K ohm 1%	Resistor		REM1-001
R32	1	01B15	100 K	Pot, 3/8 top	Panasonic	REM1-001
R33	1	1.00KX	1.00K 1%	Resistor		REM1-001

DESIGN	QUAN	PART NO	TYPE	DESCRIPTION	MFG	DRAWING #
R34	1	1.50KX	1.50K 1%	Resistor		REM1-001
R35	1	1.00KX	1.00K 1%	Resistor		REM1-001
R36	1	681X	681 1%	Resistor		REM1-001
R37	1	20.0K	20K 1%	Resistor		REM1-001
R38	1	10KQ	10K 5%	Resistor		REM1-001
R39	1	10KQ	10K 5%	Resistor		REM1-001
R40	1	10.0KX	10.0K 1%	Resistor		REM1-001
R41	1	200Q	200 5%	Resistor		REM1-001
R42	1	511KX	511K 1%	Resistor		REM1-001
R43	1	2.7KX	2.7K 5%	Resistor		REM1-001
R44	1	100KX	100K 1%	Resistor		REM1-001
R45	1	100Q	100 ohm 5%	Resistor		REM1-001
R46	1	299-10M	10M 5%	Resistor		REM1-001
R47	1	MOX-300	1000M 5%	Resistor	Victoreen	REM1-001
R48	1	1.00MX	1.00M 1%	Resistor		REM1-001
R49	1	1.00MX	1.00M 1%	Resistor		REM1-001
R50	1	100.0K	100K ohm 1%	Resistor		REM1-001
R51	1	01B15	100K	Pot, 3/4" rect	Panasonic	REM1-001
R52	1	300KX	300.0K 1%	Resistor		REM1-001
R53	1	10Q	10 ohm 5%	Resistor		REM1-001
R54	1	10Q	10 ohm 5%	Resistor		REM1-001
R55	1	499.0K	499K ohm 1%	Resistor		REM1-001
R56	1	100.0K	100K ohm 1%	Resistor		REM1-001
R57	1	100.0K	100K ohm 1%	Resistor		REM1-001
R58	1	100.0K	100K ohm 1%	Resistor		REM1-001
R59	1	100.0K	100K ohm 1%	Resistor		REM1-001
R60	1	100.0K	100K ohm 1%	Resistor		REM1-001
R61	1	100.0K	100K ohm 1%	Resistor		REM1-001
R62	1	100.0K	100K ohm 1%	Resistor		REM1-001
R63	1	100.0K	100K ohm 1%	Resistor		REM1-001
R64	1	49.9K	49.9K ohm 1%	Resistor		REM1-001
R65	1	49.9K	49.9K ohm 1%	Resistor		REM1-001
R66	1	49.9K	49.9K ohm 1%	Resistor		REM1-001
R67	1	49.9K	49.9K ohm 1%	Resistor		REM1-001
R68	1	49.9K	49.9K ohm 1%	Resistor		REM1-001
R69	1	49.9K	49.9K ohm 1%	Resistor		REM1-001
R70	1	49.9K	49.9K ohm 1%	Resistor		REM1-001
R71	1	100.0K	100K ohm 1%	Resistor		REM1-001
T1	1	T1-REM500	Pot core	Transformer	HPI	REM1-001
TP1	1	V1072-ND	T44	Stake, test point	Vector	REM1-001
TP2	1	V1072-ND	T44	Stake, test point	Vector	REM1-001
TP3	1	V1072-ND	T44	Stake, test point	Vector	REM1-001
TP4	1	V1072-ND	T44	Stake, test point	Vector	REM1-001
TP5	1	V1072-ND	T44	Stake, test point	Vector	REM1-001
TP6	1	V1072-ND	T44	Stake, test point	Vector	REM1-001
U01	1	TL064CN	TL064	Quad op amp	TI	REM1-001
U02	1	TL062CP	TL062	Dual op amp	TI	REM1-001
U03	1	CD4066NCN	4066	Switch, quad	National	REM1-001
U04	1	ADC0804LCN	ADC0804	A-D Conv 8 bit	National	REM1-001
U05	1	LM393N	LM 393	Dual Comparator	National	REM1-001
U06	1	CD4013BCN	4013	Dual D Flip Flop	National	REM1-001
U07	1	511-CD4098	4098	Mono Multivibrator	SGS	REM1-001
U08	1	LM385Z	LM 385Z	2.5 V Reference	National	REM1-001
U09	1	ICM7556IPD	ICL7665	Dual Timer	Harris	REM1-001
U10	1	TLC271CP	TLC271	Op amp	TI	REM1-001
U11	1	4094	CD4094BE	Shift Register		REM1-001
B1	6	P106	C Alkaline	Battery	Panasonic	REM1-002
BZ1	1	MEB-12-5C	Piezo	Buzzer	GPE	REM1-002
C01	1	581-4.7M10	4.7 uF 10VDC	Capacitor, tant	Thompson	REM1-002
C02	1	21RD747	47 pF	Capacitor, mono		REM1-002
C03	1	21RD722	22 pF	Capacitor, mono		REM1-002
C04	1	581-UDW104M1	.1 uF 50 VDC	Capacitor, mono	Thompson	REM1-002
C05	1	581-UDW104M1	.1 uF 50 VDC	Capacitor, mono	Thompson	REM1-002
C06	1	581-UDW104M1	.1 uF 50 VDC	Capacitor, mono	Thompson	REM1-002
C07	1	581-100M10	100 uF 10VDC	Capacitor, tant	Thompson	REM1-002
C08	1	581-33M10	33 uF 10VDC	Capacitor, tant	Thompson	REM1-002
C09	1	581-UDW104M1	.1 uF 50 VDC	Capacitor, mono	Thompson	REM1-002
C10	1	581-UDW104M1	.1 uF 50 VDC	Capacitor, mono	Thompson	REM1-002
C11	1	581-UDW104M1	.1 uF 50 VDC	Capacitor, mono	Thompson	REM1-002
C12	1	581-UDW104M1	.1 uF 50 VDC	Capacitor, mono	Thompson	REM1-002
C13	1	581-UDW104M1	.1 uF 50 VDC	Capacitor, mono	Thompson	REM1-002
C14	1	581-UDW104M1	.1 uF 50 VDC	Capacitor, mono	Thompson	REM1-002
C15	1	581-UDW104M1	.1 uF 50 VDC	Capacitor, mono	Thompson	REM1-002
C16	1	581-UDW104M1	.1 uF 50 VDC	Capacitor, mono	Thompson	REM1-002
C17	1	581-UDW104M1	.1 uF 50 VDC	Capacitor, mono	Thompson	REM1-002
C18	1	581-47M16	47 uF 16 VDC	Capacitor, tant	Thompson	REM1-002
C19	1	581-47M16	47 uF 16 VDC	Capacitor, tant	Thompson	REM1-002
C20	1	581-47M16	47 uF 16 VDC	Capacitor, tant	Thompson	REM1-002
C21	1	581-47M16	47 uF 16 VDC	Capacitor, tant	Thompson	REM1-002
C22	1	581-47M16	47 uF 16 VDC	Capacitor, tant	Thompson	REM1-002
C23	1	581-47M16	47 uF 16 VDC	Capacitor, tant	Thompson	REM1-002
C24	1	21RD710	10 pF	Capacitor, mono		REM1-002
C25	1	21RD710	10 pF	Capacitor, mono		REM1-002
C26	1	581-10M10	10 uF 10 VDC	Capacitor, tant	Thompson	REM1-002
C27	1	581-10M10	10 uF 10 VDC	Capacitor, tant	Thompson	REM1-002
C28	1	581-10M10	10 uF 10 VDC	Capacitor, tant	Thompson	REM1-002
C29	1	581-10M10	10 uF 10 VDC	Capacitor, tant	Thompson	REM1-002
D01	1	1N4148PH	1N4148	Diode	Philips	REM1-002
D02	1	1N4002GI	1N4002	Diode	Gen Inst	REM1-002
D03	1	1N4148PH	1N4148	Diode	Philips	REM1-002
D04	1	1N4148PH	1N4148	Diode	Philips	REM1-002
D05	1	1N4148PH	1N4148	Diode	Philips	REM1-002
D06	1	1N4148PH	1N4148	Diode	Philips	REM1-002
D07	1	1N5817	Schottky	Diode	Dio Inc	REM1-002
D08	1	1N5817	Schottky	Diode	Dio Inc	REM1-002

DESIGN	QUAN	PART NO	TYPE	DESCRIPTION	MFG	DRAWING #
J1	1	CHR26G-ND	26 Pin RA HDR .1x.1	Connector	CW Ind	REM1-002
J2	1	WM4204	4 Pin SIP HDR	Connector	Molex	REM1-002
J4	1	WM4205	7 Pin SIP HDR .1	Connector	Molex	REM1-002
L1	1	EM-R1A	12 V	Electromagnet	Magnet Sal	REM1-002
P1	1	CHR26G-ND	26 Pin RA HDR .1x.1	Connector	CW Ind	REM1-002
P2	1	WM2002	4 Pin SIP WIRE	Connector	Molex	REM1-002
P3	1	CHS26G-ND	26 Pin ST HDR .1x.1	Connector	CW Ind	REM1-002
Q1	1	VN10KM	N PWR	FET		REM1-002
Q2	1	VN10KM	N PWR	FET		REM1-002
Q3	1	VN10KM	N PWR	FET		REM1-002
Q4	1	VN10KM	N PWR	FET		REM1-002
Q4	1	VN10KM	N PWR	FET		REM1-002
Q5	1	VN10KM	N PWR	FET		REM1-002
R01	1	100KQ	100K 5%	Resistor		REM1-002
R02	1	1MΩ	1M 5%	Resistor		REM1-002
R03	1	100KQ	100K 5%	Resistor		REM1-002
R04	1	100KX	100.0K 1%	Resistor		REM1-002
R05	1	36C24	20 K 1t 6mm	Potentiometer	Panasonic	REM1-002
R06	1	49.9KX	49.9K 1%	Resistor		REM1-002
R07	1	49.9KX	49.9K 1%	Resistor		REM1-002
R08	1	49.9KX	49.9K 1%	Resistor		REM1-002
R09	1	100KX	100.0K 1%	Resistor		REM1-002
R10	1	100KX	100.0K 1%	Resistor		REM1-002
R11	1	100KX	100.0K 1%	Resistor		REM1-002
R12	1	100KX	100.0K 1%	Resistor		REM1-002
R13	1	100KX	100.0K 1%	Resistor		REM1-002
R14	1	10KQ	10K 5%	Resistor		REM1-002
R15	1	10Q	10 5%	Resistor		REM1-002
R16	1	49.9KX	49.9K 1%	Resistor		REM1-002
R17	1	29MF250-1.5M	1.5M 1%	Resistor		REM1-002
R18	1	499KX	499K 1%	Resistor		REM1-002
R19	1	100KQ	100K 5%	Resistor		REM1-002
R20	1	10KQ	10K 5%	Resistor		REM1-002
R21	1	120KQ	120K 5%	Resistor		REM1-002
R22	1	1.5MΩ	1.5M 5%	Resistor		REM1-002
R23	1	390KQ	390K 5%	Resistor		REM1-002
R24	1	3.3KQ	3.3K 5%	Resistor		REM1-002
R25	1	100KQ	100K 5%	Resistor		REM1-002
RN1	1	770-101-R100K	100K x 9	Resistor network	CTS	REM1-002
RN2	1	770-101-R10K	10K x 9	Resistor network	CTS	REM1-002
S1	1	P8037S	Push SPST	Switch tiny	Panasonic	REM1-002
S2	1	P8037S	Push SPST	Switch tiny	Panasonic	REM1-002
S3	1	P8036S	Push SPST	Switch	Panasonic	REM1-002
S4	1	P8036S	Push SPST	Switch	Panasonic	REM1-002
S5	1	P8036S	Push SPST	Switch	Panasonic	REM1-002
S6	1	P8036S	Push SPST	Switch	Panasonic	REM1-002
S7	1	P8036S	Push SPST	Switch	Panasonic	REM1-002
S8	1	P8036S	Push SPST	Switch	Panasonic	REM1-002
TP1	1	V1072-ND	T44	Stake	Vector	REM1-002
TP2	1	V1072-ND	T44	Stake	Vector	REM1-002
TP3	1	V1072-ND	T44	Stake	Vector	REM1-002
U01	1	NSC800N-3I	NSC800	Microprocessor 8 bit	National	REM1-002
U02	1	MM74HC574N	74HC574	Octal D F/F	National	REM1-002
U03	1		27C64	EPROM		REM1-002
U04	1	UM6116-3L	6116	RAM 1K x 8		REM1-002
U05	1	TLC271CP		Op Amp	TI	REM1-002
U06	1	SSM2160MYB-G	16 x 2 w/bklt LED	LCD alphanumeric	SHELLY	REM1-002
U07	1	MM74HC08N	74HC08	Quad AND	National	REM1-002
U08	1	MM74HC02N	74HC02	Quad Nor gate	National	REM1-002
U09	1	MM74HC04	74HC04	Hex inverter	National	REM1-002
U10	1	MM74HC138N	74HC138	3 to 8 Decoder	National	REM1-002
U11	1	MM74HC74AN	74HC74	Dual Flip Flop	National	REM1-002
U12	1	ICL7665CPA	ICL7665	Voltage Detector	Maxim	REM1-002
U13	1	511-4069	4069	Hex Inverter	SGS	REM1-002
U14	1	LM2931T-5.0	LM 2931	5 V Regulator TO220	National	REM1-002
U15	1	NSC810AN-3I	NSC810	PIA Interface	National	REM1-002
U16	1	93C46P	93C46	EEPROM 1K	ICT	REM1-002
U17	1	ICL7660SCPA	ICL7660	Volt Converter	Harris	REM1-002
U18	1	ICL7660SCPA	ICL7660	Volt Converter	Harris	REM1-002
U19	1	SCC2691AC1N24	SCC2691	UART	Signetics	REM1-002
U20	1	MAX232CPE	MAX232CPE	Volt Conv RS232	Maxim	REM1-002
X1	1	CTX080	4.000 MHz	Crystal	CTS	REM1-002
X2	1	CTX049	3.6864 MHz	Crystal	CTS	REM1-002
M01	1	11093-A-1032-1B	HANDLE		Amatom	REM1-023
M02	1	REM1-007		Top Plate	HPI	REM1-023
M03	1	REM1-015		Switch Panel	HPI	REM1-023
M04	1	REM1-004		Shield, Analog Bd	HPI	REM1-023
M05	1		LEXAN	WINDOW	HPI	REM1-023
M06	1			GASKET, SWITCH	HPI	REM1-023
M07	1	REM1-002		DIGITAL CIRCUIT BD	HPI	REM1-023
M08	1	REM1-002		CIRCUIT BD ANALOG	HPI	REM1-023
M09	1	REM1-0021		PCB FRONT PANEL	HPI	REM1-023
M10	1	See REM1-018		LCD DISPLAY		REM1-023
M11	1	REM1-025-2		Cable, Ribbon	HPI	REM1-023
M12	1	REM1-025-3		Cable, Ribbon	HPI	REM1-023
M13	1	REM1-025-1		Cable, Ribbon	HPI	REM1-023
M14	4		6-32 x 5/8	Screw, Pan Phil PS		REM1-023
M15	6		#6	Washer, Nylon		REM1-023
M16	2		10-32 x 1/2	Screw, Pan Phil PS		REM1-023
M17	4		6-32 x 3/8	Screw, Set SS		REM1-023
M18	2	354K-ND	6-32 x 1 FF	Spacer, Angle	Keystone	REM1-023
M19	2	J181	6-32 x 1	Spacer, Hex	EF JOHNSON	REM1-023
M20	20		6-32 x 1/4	Screw, PAN PH PS		REM1-023
M21	26		#6 Int Star	Lockwasher		REM1-023
M22	2	353K-ND	6-32 x 3/4 FF	Spacer, Angle	Keystone	REM1-023

DESIGN	QUAN	PART NO	TYPE	DESCRIPTION	MFG	DRAWING #
M23	2	J246	6-32 x 7/8	Spacer, Rnd	EF Johnson	REM1-023
M24	4		6-32 x 1/8	Screw, Pan PH PS		REM1-023
M25	4		2-56 x 3/8	Screw, Pan PH PS		REM1-023
M26	4	J230	#4 x 1/8	Spacer, Nylon	EF Johnson	REM1-023
M27	4	313-1437-014	#6 x 7/16	Spacer, Rnd	EF Johnson	REM1-023
M28	4		#2	Lockwasher, Int Star		REM1-023
M29	4		2-56	Nut, Hex PS		REM1-023
M30	4		6-32 x 3/4	Screw, Pan PH PS		REM1-023
M31	5	REM1-026	Nylon	Spacer, Button		REM1-023
M32	5	J178	6-32 x 1/2	Spacer, Hex	EF Johnson	REM1-023
M33	1		1/8 x 18"	O ring, Rubber		REM1-023
M34	2		6-32 x 3/8	Screw, Pan PH PS		REM1-023
M35	2	J168	#6 x 1/8	Spacer, Rnd	EF Johnson	REM1-023
M36	1		4-40 x 1/2	Screw, Pan Nylon		REM1-023
M37	1		4-40	Nut, Nylon		REM1-023
M01	1	REM1-005		Box, Battery top	HPI	REM1-024
M02	1	REM1-006		Box, Battery Bottom	HPI	REM1-024
M03	1	REM1-011		Batt End Plate	HPI	REM1-024
M04	1	REM1-010		Bracket, Bottom	HPI	REM1-024
M05	1	REM1-008		Battery Cover	HPI	REM1-024
M06	1	REM1-013		Bottom Can	HPI	REM1-024
M07	1	REM1-014		Magnet Housing	HPI	REM1-024
M08	1	REM1-009		Bracket, Top	HPI	REM1-024
M09	1	REM1-003		Cover, Preamp	HPI	REM1-024
M10	1	REM1-0041		Preamp PCB	HPI	REM1-024
M11	1	REM1-LET		Detector	HPI	REM1-024
M12	1	REM1-028	Neoprene	Gasket, Detector	HPI	REM1-024
M13	1		12VDC	Electromagnet		REM1-024
M14	2			Ball Plungers		REM1-024
M15	4	99-600-9	#6	Thumbscrew Cap	SPI	REM1-024
M17	4		6-32 x 1/4	Ssrew, Pan PH PS		REM1-024
M18	4		#6	Lockwasher, Int Star		REM1-024
M19	4		6-32 x 1/4	Screw, Pan PH PS		REM1-024
M20	4		6-32 x 3/8	Spacer, Hex		REM1-024
M21	4		6-32 x 3/8	Screw, SHCS SS		REM1-024
M22	2	REM1-028		Battery Contact	HPI	REM1-024
M23	4		6-32	Nut, Hex PS		REM1-024
M24	3		10-32	Nut, Hex PS		REM1-024
M25	2		#10	Lockwasher, Int Star		REM1-024
M26	10	S/6-32 x 1/4	6-32 x 1/4	Screw, Pan Sealing	APM Hexsel	REM1-024
M27	3		4-40 x 1/2	Screw, CS PH 100deg		REM1-024
M28	2		10-32 x 1/2	Screw, Set SS		REM1-024
M29	1		10-32 x 5/16	Screw, Set SS		REM1-024
M30	3		4-40	Nut, Hex PS		REM1-024
M31	6		#4	Lockwasher, Int Star		REM1-024
M32	3	313-6487-020	4-40 x 5/8	Spacer, Hex	EF Johnson	REM1-024
M33	3		#4	Washer PS		REM1-024
M34	2		6-32 x 3/8	Screw, Set SS		REM1-024
M35	1	REM1-025-4		Cable, SIP	HPI	REM1-024
M36	4		6-32 x 3/8	Screw, Pan PH PS		REM1-024
M37	3		4-40 x 1/4	Screw, Pan PH PS		REM1-024
M38	1		10-32 x 1/4	Screw, PHCS SS		REM1-024
P1	1	CKC26G-ND	26 pin	Socket Connector	CW	REM1-025
P2	1	CKC26G-ND	26 pin	Socket Connector	CW	REM1-025
P3	1	CKC26G-ND	26 pin	Socket Connector	CW	REM1-025
P4	1	CKC26G-ND	26 pin	Socket Connector	CW	REM1-025
P5	1	CKC10G-ND	26 pin	Socket Connector	CW	REM1-025
P6	1	CKC10G-ND	26 pin	Socket Connector	CW	REM1-025
P7	1	WM2002	4 pin	Terminal Housing	Molex	REM1-025
P7-A	4	WM2200	.1 Tin	Pins for housing	Molex	REM1-025
W1	1	R025-ND	26 conductor 6"long	Cable, Ribbon	OKI	REM1-025
W2	1	R020-ND	10 conductor 10"long	Cable, Ribbon	OKI	REM1-025
W3	1	R025-ND	26 conductor 3"long	Cable, Ribbon	OKI	REM1-025

XXV. PARTS LOCATIONS AND SCHEMATICS

PARTS LOCATION CIRCUIT BOARD

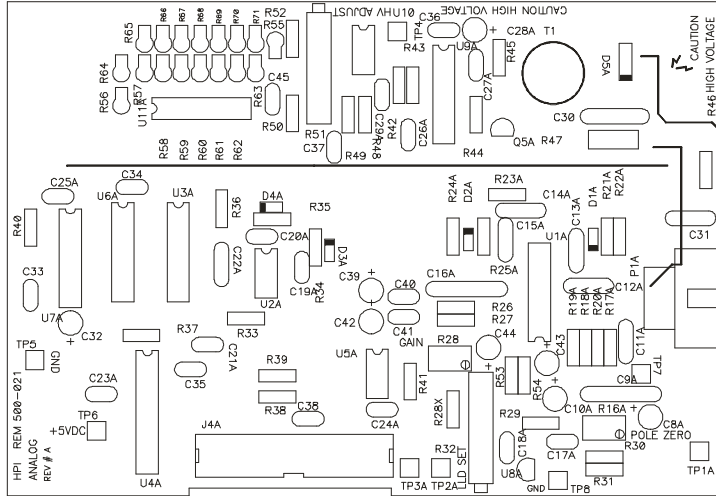

ANALOG BOARD

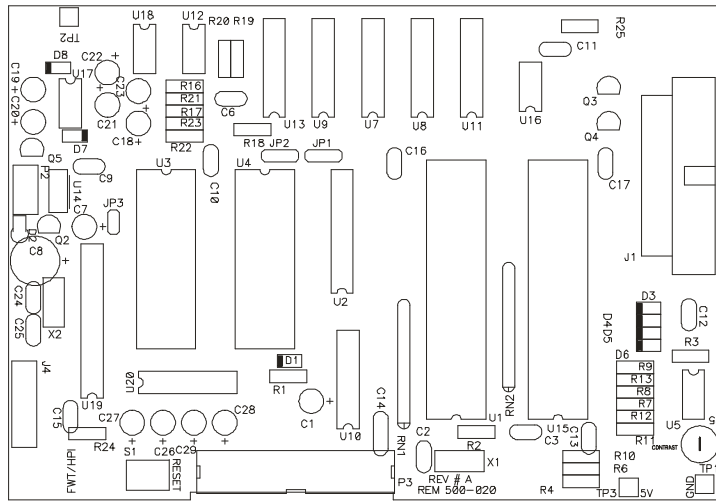

DIGITAL BOARD

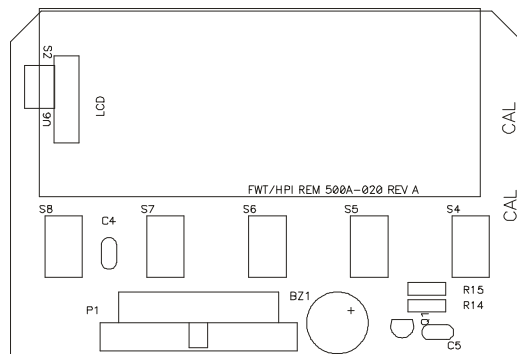

DISPLAY BOARD

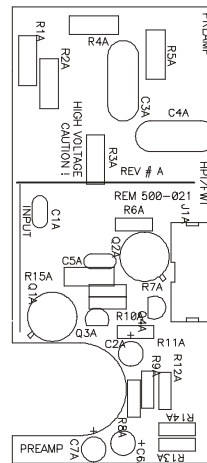

PREAMP BOARD

PARTS LOCATION TOP SECTION

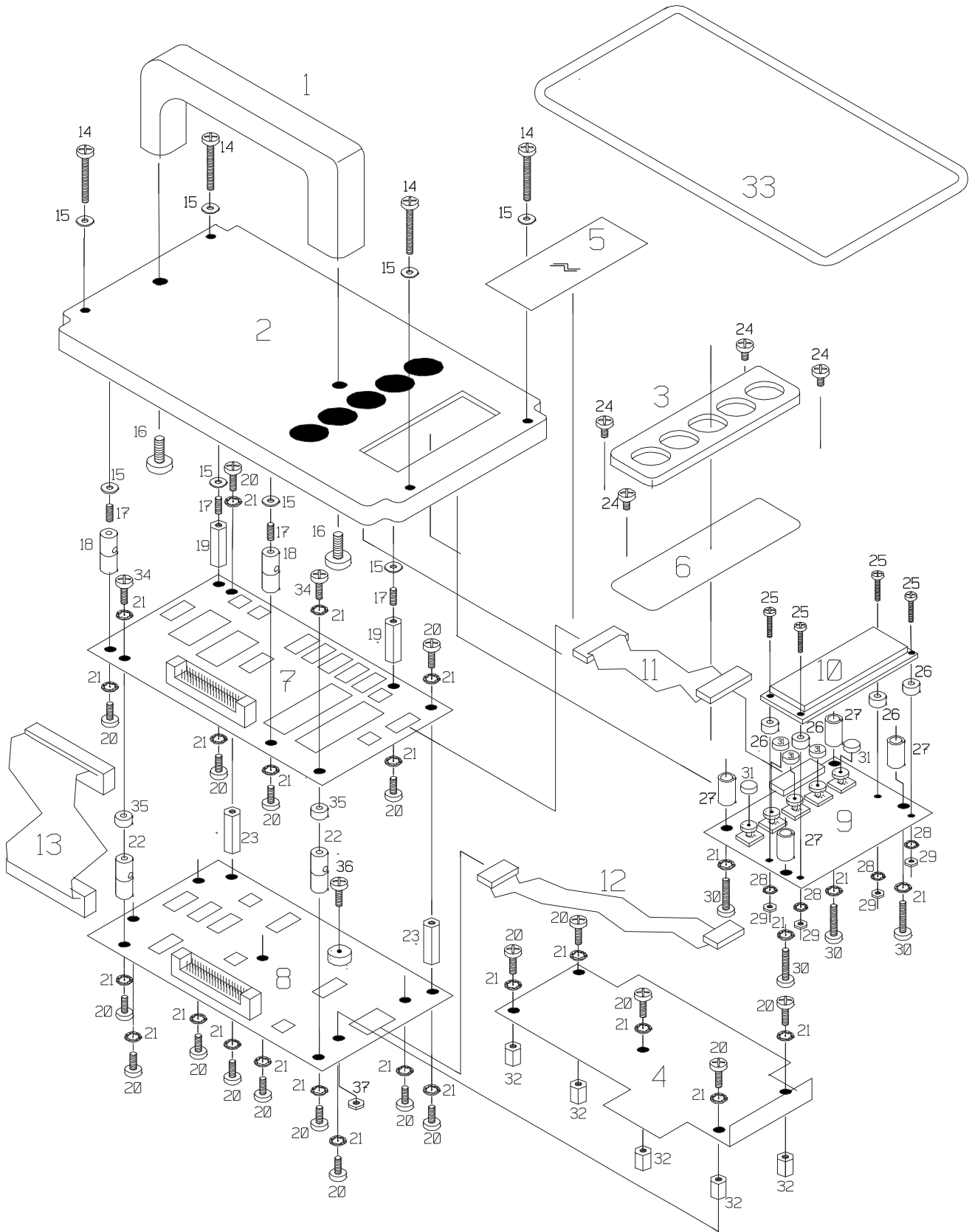

PARTS LOCATION BOTTOM SECTION

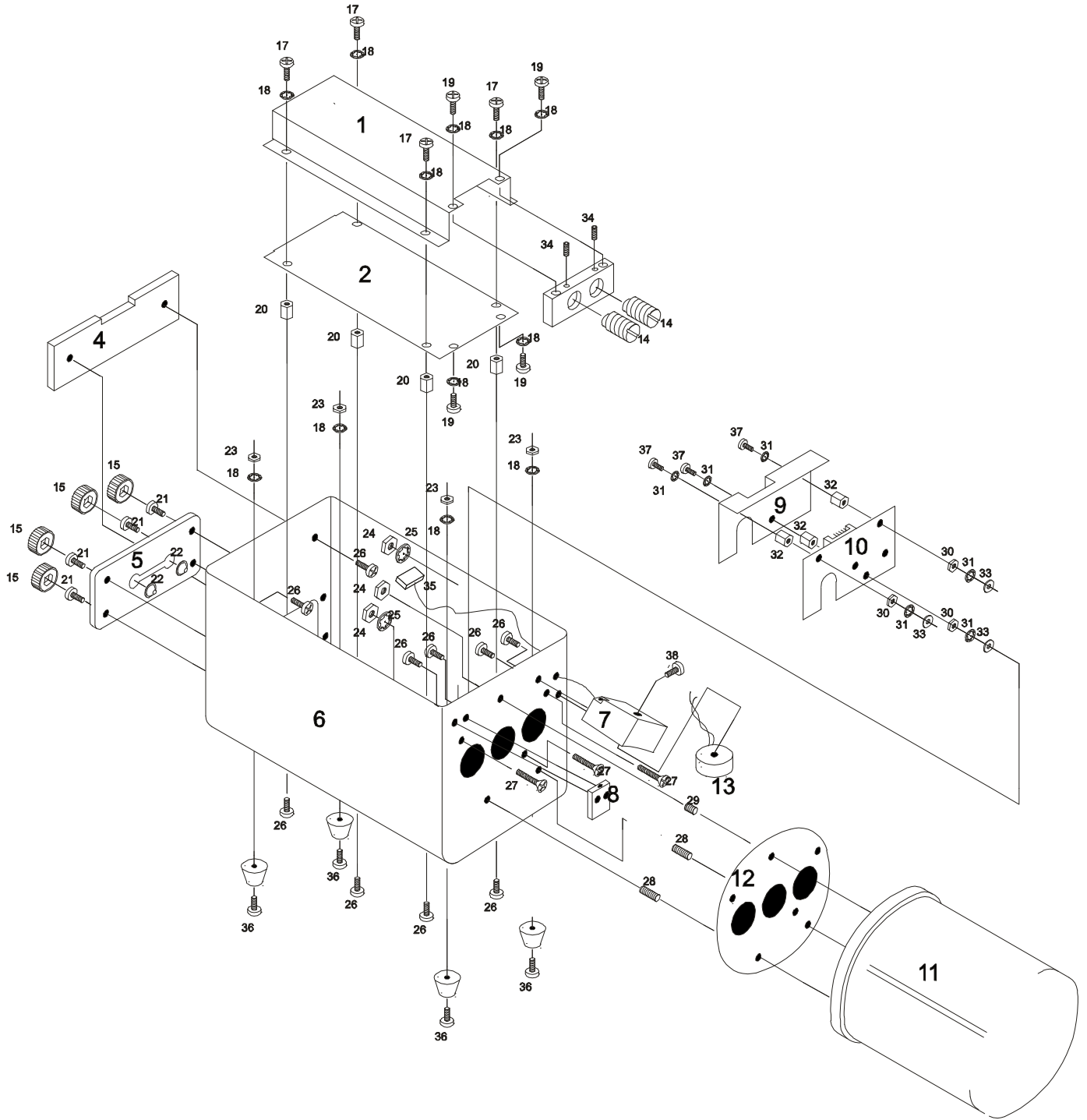

SCHEMATICS

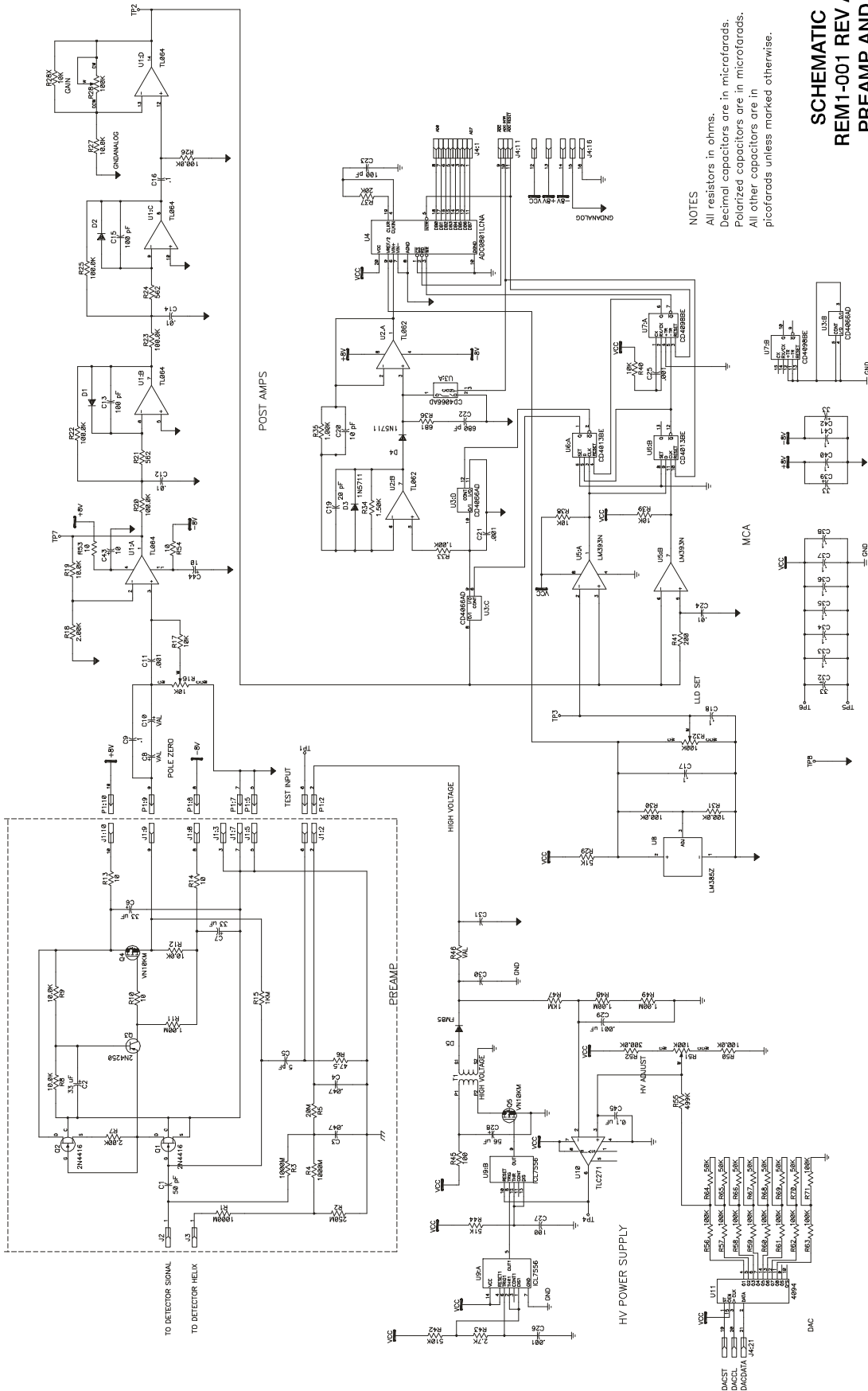

SCHEMATIC REM1-001 REV A PREAMP AND ANALOG BOARD

NOTES
All resistors in ohms.
Decimal capacitors are in microfarads.
Polarized capacitors are in microfarads.
All other capacitors are in picofarads unless marked otherwise.

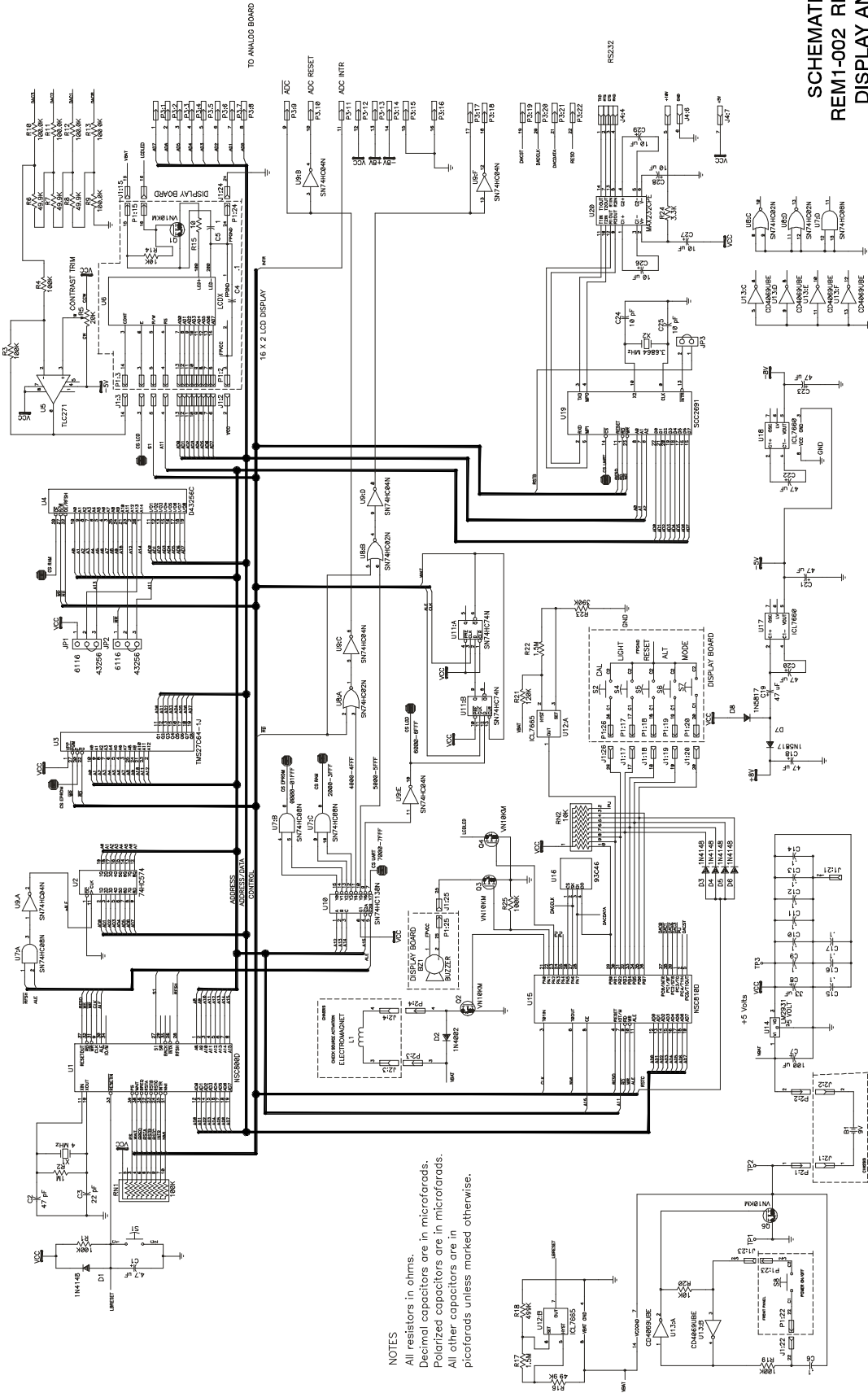

**SCHEMATIC
REM1-002 REV A
DISPLAY AND
DIGITAL BOARD**

NOTES
 All resistors in ohms.
 Decimal capacitors are in microfarads.
 Polarized capacitors are in millifarads.
 All other capacitors are in picofarads unless marked otherwise.